

SURVEY STATION TABLE				
STN No	CODE	EASTING	NORTHING	RL
10	NAIL IN CONCRETE	925785.15	6251991.61	6.11
11	NAIL IN CONCRETE	925762.13	6252000.01	4.03
14	NAIL IN CONCRETE	925637.59	6251893.47	7.78
16	NAIL IN KERB	925741.64	6252118.86	3.7
18	NAIL IN KERB	925683.38	6252103.18	3.92
19	NAIL IN KERB	925587.74	6252077.46	8.54

**NOTES**

- THE PURPOSE OF THIS PLAN IS FOR DESIGN ONLY. CURRENT PLANS ISSUED BY SERVICE PROVIDERS THROUGH 'DIAL BEFORE YOU DIG' ARE STILL REQUIRED. CONTRACTORS AND SUBCONTRACTORS WILL NEED TO EXERCISE THEIR OWN 'DUTY OF CARE' AND SHOULD MAKE THEIR OWN DIAL BEFORE YOU DIG ENQUIRY BEFORE EXCAVATION/CONSTRUCTION. YOU MUST ENSURE 'DIAL BEFORE YOU DIG' ARE CURRENT AS THEY HAVE VARYING EXPIRATION DATES, AND MAY REQUIRE RE-ISSUE OTHERWISE THE INFORMATION ON THIS PLAN MAY NO LONGER BE CURRENT.
- WARNING: UNKNOWN SERVICES MAY EXIST THAT COULD NOT BE ELECTRONICALLY DETECTED. THE DIAGRAMS OF THE SERVICE PROVIDER MAY NOT DEPICT ALL ASSETS WITHIN THEIR NETWORK AND SERVICE PROVIDERS MAY SHARE CONDUITS AND /OR TRENCHES AT THIS LOCATION.
- WARNING: SINGLE MARKED LINES MAY REPRESENT MULTIPLE CONDUITS, PIPES END/OR CABLES AT THIS LOCATION. THE RECORDING OF DEPTHS AND POSITION OF UTILITIES CANNOT BE GUARANTEED AS CORRECT. WE RECOMMEND NON DESTRUCTIVE DIGGING/POTHOLING TO EXPOSE SERVICES FOR ACCURATE IDENTIFICATION AND DEPTH.
- CAUTION: SERVICE LOCATING COMPANY HAVE SURVEYED AND MARKED OUT EXISTING SERVICES IN THE AREA SPECIFIED BY THE CLIENT. THESE SERVICE LINES HAVE BEEN LOCATED BY ABOVE GROUND SERVICE TRACING METHODS AND HAVE NOT BEEN SIGHTED. CMS SURVEYORS HAVE THEN LOCATED THE LINE MARKED BY SERVICE LOCATING COMPANY. THE LOCATION OF THESE MARKED SERVICES ARE APPROXIMATE ONLY. THE POSITION OF THE MARKED SERVICE LINES HAS BEEN MADE WITH REFERENCE TO THE RELEVANT SERVICE AUTHORITY DIAGRAMS. ALL SERVICES MAY NOT HAVE BEEN SHOWN AND UTILITY DESCRIPTIONS HAVE BEEN TAKEN FROM UTILITY PROVIDED DIAGRAMS WHERE AVAILABLE. WE RECOMMEND NON DESTRUCTIVE DIGGING/POTHOLING TO EXPOSE MARKED SERVICES TO IDENTIFY AND SHOW EXACT DEPTH AND LOCATION OF SERVICE LINES PRIOR TO EARTHWORKS COMMENCING. UTILITIES PLOTTED ON THE PLAN THAT TERMINATE IN THE SPECIFIED AREA MAY GO TO FEATURES THAT HAVE NOT BEEN SHOWN ON THE BACKGROUND DETAIL SURVEY PROVIDED BY CLIENT. THE RISK REMAINS WITH THE CLIENT AND/OR SUB CONTRACTOR AND THEIR RESPONSIBILITY TO EXERCISE CAUTION AT ALL TIMES.

**LEGEND: (SEE NOTES)**

- c- = COMMUNICATIONS LINES (UNDERGROUND)
- EO- = ELECTRICITY LINES (OVERHEAD)
- Eo- = ELECTRICITY LINE (UNDERGROUND)
- G- = GAS LINE
- S- = SEWER LINE (UNDERGROUND)
- sw- = STORMWATER LINE
- W- = WATER (FIRE) (UNDERGROUND)
- W- = WATER BULK SUPPLY MAIN (UNDERGROUND)

**LEGEND:**

- BB = BOTTOM OF BANK
- BIN = RUBBISH BIN
- BIT = BITUMEN
- BL = BALCONY
- BLD = EXTERNAL BUILDING
- BOL = BOLLARD
- BW = BOTTOM WALL
- CL = CENTRELINE
- COL = COLUMN
- COM = COMMUNICATIONS PIT
- CON = CONCRETE
- CU= COMMUNICATIONS LEVEL UNDERGROUND
- DK = DECK
- DS = DOOR SILL LEVEL
- ELP = ELECTRICITY
- EPL = ELECTRICITY PILLAR
- EU=ELECTRICITY LEVEL UNDERGROUND
- FCE = FENCE
- FL = FLOOR LEVEL
- GAR = GARAGE
- GDN = GARDEN
- GF = GUTTER LEVEL
- GFL = GARAGE FLOOR LEVEL
- GP = GAS PLAQUE
- GR = GRAVEL
- GRT = GRATE
- GU = GAS UNDER
- HL = HOOD LEVEL
- HYD = HYDRANT
- IL = INVERT LEVEL
- LID = MISCELLANEOUS PIT LID
- LIN = LINTEL
- LM = LINE MARKING
- LP = LIGHT POLE
- NS = NATURAL SURFACE
- PAR = PARAPET
- PAT = PATIO
- PAV = PAVING
- PIT = TOP OF PIT LEVEL
- POST=
- PP = POWER POLE
- REND = RENDERED
- RET = RETAINING
- RF = TOP OF ROOF
- RR = ROOF RIDGE
- SCN = SCREEN
- SGN = SIGN
- SIP = SEWER INSPECTION PIT
- SL = SILL LEVEL
- SMH = SEWER MAN HOLE
- STR = STAIRS
- SU = SEWER LEVEL UNDERGROUND
- SV = STOP VALVE
- TB = TOP OF BANK
- TEL = TELSTRA
- TER = TERRACE
- TFCE = TOP OF FENCE
- TG = TOP OF GUTTER
- TKB = TOP OF KERB
- TP = TAP
- TP = TOP OF PIPE
- TR = TREE
- TRL = TREE LINE
- TW = TOP WALL
- UNS = UNDERSIDE
- UP = TOWN WATER UNDER
- VA = VALVE
- VER = VERANDAH
- WM = WATER METER
- WU = WATER LEVEL UNDERGROUND
- EO- = ELECTRICITY OVERHEAD
- S- = SEWER UNDERGROUND

TREE  
 Ø = TRUNK DIAMETER  
 H = HEIGHT  
 S = SPREAD DIAMETER

**NOTES**

- IF CONSTRUCTION ON OR NEAR BOUNDARIES IS REQUIRED IT IS RECOMMENDED THAT THE BOUNDARIES OF THE LAND BE MARKED.
- TREE SIZES ARE ESTIMATES ONLY.
- THIS PLAN HAS BEEN PREPARED FOR THE EXCLUSIVE USE OF FRESHFOOD AUSTRALIA HOLDINGS PTY LTD
- RELATIONSHIP OF IMPROVEMENTS TO BOUNDARIES IS DIAGRAMMATIC ONLY. WHERE OFFSETS ARE CRITICAL THEY SHOULD BE CONFIRMED BY FURTHER SURVEY.
- EXCEPT WHERE SHOWN BY DIMENSION LOCATION OF DETAIL WITH RESPECT TO BOUNDARIES IS INDICATIVE ONLY.
- SEWER MAIN PLOTTED FROM SYDNEY WATER SEWER DIAGRAM. LOCATION SHOULD BE MARKED ON SITE IF CRITICAL.
- CRITICAL SPOT LEVELS SHOULD BE CONFIRMED WITH SURVEYOR.
- THIS PLAN IS ONLY TO BE USED FOR THE PURPOSE OF DESIGNING NEW CONSTRUCTIONS.
- CONTOURS SHOWN DEPICT THE TOPOGRAPHY. THEY DO NOT REPRESENT THE EXACT LEVEL AT ANY PARTICULAR POINT. ONLY SPOT LEVELS SHOULD BE USED FOR CALCULATIONS OF QUANTITIES WITH CAUTION.
- CONTOUR INTERVAL - 0.5 metre - SPOT LEVELS SHOULD BE ADOPTED.
- POSITION OF RIDGE LINES ARE DIAGRAMMATIC ONLY (NOT TO SCALE).
- THE INFORMATION IS ONLY TO BE USED AT A SCALE ACCURACY OF 1:200.
- DO NOT SCALE OFF THIS PLAN / FIGURED DIMENSIONS TO BE TAKEN IN PREFERENCE TO SCALED READINGS.
- COPYRIGHT © CMS SURVEYORS 2015.
- NO PART OF THIS SURVEY MAY BE REPRODUCED, STORED IN A RETRIEVAL SYSTEM OR TRANSMITTED IN ANY FORM, WITHOUT THE WRITTEN PERMISSION OF THE COPYRIGHT OWNER EXCEPT AS PERMITTED BY THE COPYRIGHT ACT 1968.
- ANY PERMITTED DOWNLOADING, ELECTRONIC STORAGE, DISPLAY, PRINT, COPY OR REPRODUCTION OF THIS SURVEY SHOULD CONTAIN NO ALTERATION OR ADDITION TO THE ORIGINAL SURVEY.
- THIS NOTICE MUST NOT BE ERASED.

**KEY PLAN**

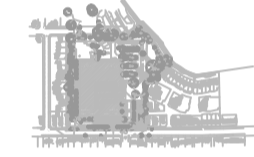

**HORIZONTAL DATUM:**  
CO-ORDINATE SYSTEM: MGA

**VERTICAL DATUM:**  
DATUM: AUSTRALIAN HEIGHT DATUM (AHD)  
B.M. ADOPTED: SSM.122287  
R.L. 6.019 (ORDER L3)  
SOURCE: S.C.I.M.S. (30/04/15)

1 FIRST ISSUE 16/06/15

**CLIENT:**  
**FRESHFOOD AUSTRALIA HOLDINGS PTY LTD**  
**C/- NIXANDERSON PTY LTD**  
**17 CHUTER STREET**  
**McMAHONS POINT NSW 2060**

**SURVEY PLAN**  
**SHOWING DETAIL & LEVELS**  
**OVER LOT 5 IN D.P.129325,**  
**LOT 398 & 399 IN D.P.752023**  
**AND LOT 2 IN D.P.230294**  
**160 BURWOOD ROAD**  
**CONCORD NSW 2137**

**C.M.S. Surveyors**  
**Pty Limited**

ACN: 096 240 201  
PO Box 463 Dee Why  
NSW 2099  
1/32 Campbell Avenue,  
Dee Why NSW 2099  
Telephone: (02) 9971 4802  
Facsimile: (02) 9971 4822  
E-mail: info@cmsurveyors.com.au

LGA: CANADA BAY		SHEET 1 OF 11	
SURVEYED MB	DRAWN CJR	CHECKED MB	APPROVED MJ
SURVEY INSTRUCTION 13040		SCALE 1:800 @ A1	DATE OF SURVEY 12/05/15
DRAWING NAME <b>13040detail 3</b>			ISSUE 1
CAD FILE 13040detail 3.dwg			

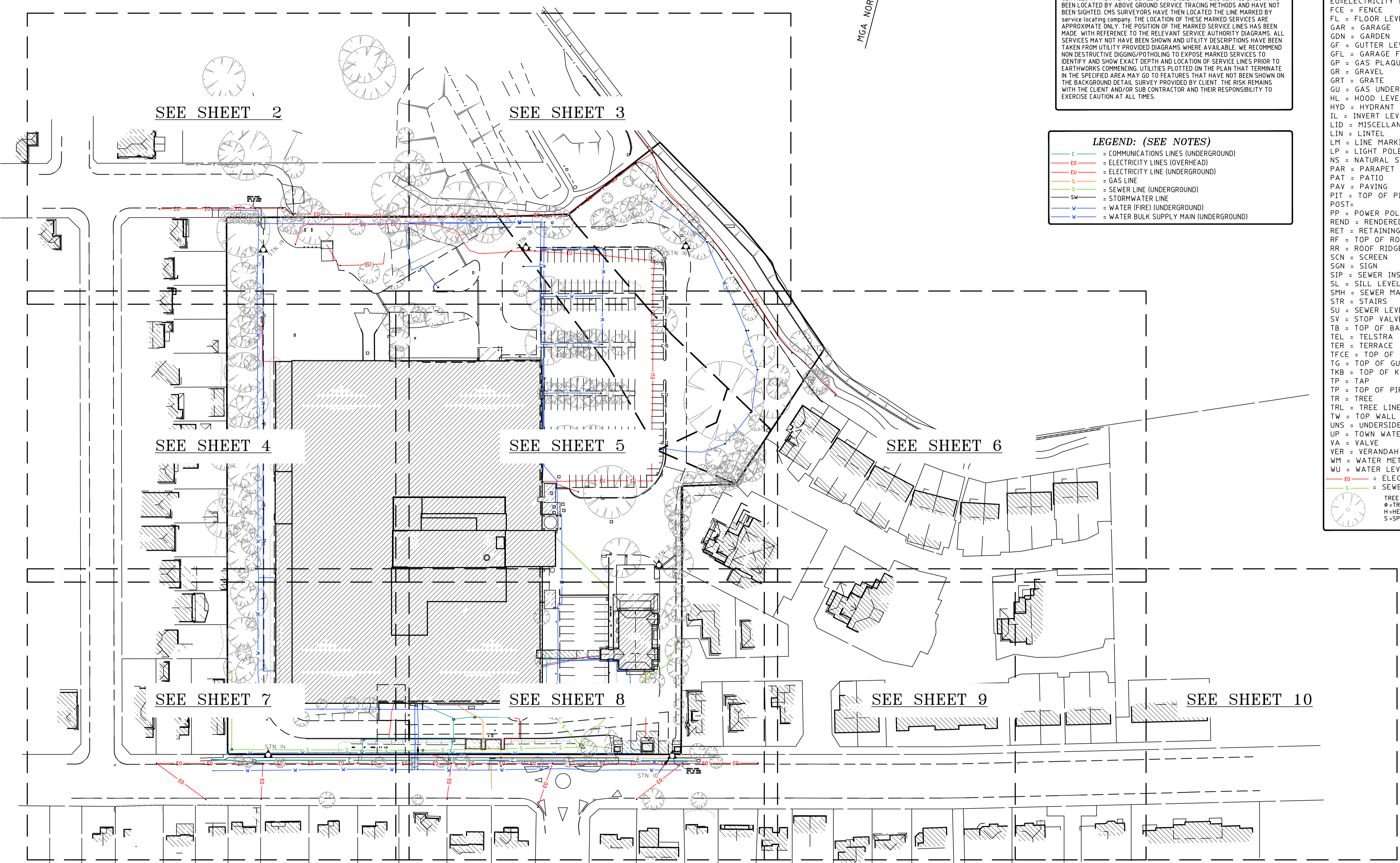

SEE SHEET 2

SEE SHEET 3

SEE SHEET 4

SEE SHEET 5

SEE SHEET 6

SEE SHEET 7

SEE SHEET 8

SEE SHEET 9

SEE SHEET 10



THIS SHEET IS TO BE READ IN CONJUNCTION WITH NOTES & LEGEND SEE SHEET 11

- IF CONSTRUCTION ON OR NEAR BOUNDARIES IS REQUIRED IT IS RECOMMENDED THAT THE BOUNDARIES OF THE LAND BE MARKED.
- TREE SIZES ARE ESTIMATES ONLY.
- THIS PLAN HAS BEEN PREPARED FOR THE EXCLUSIVE USE OF FRESHFOOD AUSTRALIA HOLDINGS PTY LTD
- RELATIONSHIP OF IMPROVEMENTS TO BOUNDARIES IS DIAGRAMMATIC ONLY. WHERE OFFSETS ARE CRITICAL THEY SHOULD BE CONFIRMED BY FURTHER SURVEY.
- EXCEPT WHERE SHOWN BY DIMENSION LOCATION OF DETAIL WITH RESPECT TO BOUNDARIES IS INDICATIVE ONLY.
- SEWER MAIN PLOTTED FROM SYDNEY WATER SEWER DIAGRAM. LOCATION SHOULD BE MARKED ON SITE IF CRITICAL.
- CRITICAL SPOT LEVELS SHOULD BE CONFIRMED WITH SURVEYOR.
- THIS PLAN IS ONLY TO BE USED FOR THE PURPOSE OF DESIGNING NEW CONSTRUCTIONS.
- CONTOURS SHOWN DEPICT THE TOPOGRAPHY. THEY DO NOT REPRESENT THE EXACT LEVEL AT ANY PARTICULAR POINT. ONLY SPOT LEVELS SHOULD BE USED FOR CALCULATIONS OF QUANTITIES WITH CAUTION.
- CONTOUR INTERVAL - 0.5 metre. - SPOT LEVELS SHOULD BE ADOPTED.
- POSITION OF RIDGE LINES ARE DIAGRAMMATIC ONLY (NOT TO SCALE).
- THE INFORMATION IS ONLY TO BE USED AT A SCALE ACCURACY OF 1:200.
- DO NOT SCALE OFF THIS PLAN / FIGURED DIMENSIONS TO BE TAKEN IN PREFERENCE TO SCALED READINGS.
- COPYRIGHT © CMS SURVEYORS 2015.
- NO PART OF THIS SURVEY MAY BE REPRODUCED, STORED IN A RETRIEVAL SYSTEM OR TRANSMITTED IN ANY FORM, WITHOUT THE WRITTEN PERMISSION OF THE COPYRIGHT OWNER EXCEPT AS PERMITTED BY THE COPYRIGHT ACT 1968.
- ANY PERMITTED DOWNLOADING, ELECTRONIC STORAGE, DISPLAY, PRINT, COPY OR REPRODUCTION OF THIS SURVEY SHOULD CONTAIN NO ALTERATION OR ADDITION TO THE ORIGINAL SURVEY.
- THIS NOTICE MUST NOT BE ERASED.

KEY PLAN

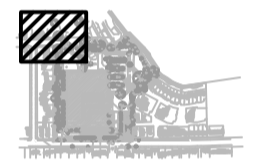

HORIZONTAL DATUM:  
CO-ORDINATE SYSTEM: MGA

VERTICAL DATUM:  
DATUM: AUSTRALIAN HEIGHT DATUM (AHD)  
B.M. ADOPTED: SSM.I22287  
R.L. 6.019 (ORDER L3)  
SOURCE: S.C.I.M.S. (30/04/15)

1	FIRST ISSUE	16/06/15
---	-------------	----------

CLIENT:  
**FRESHFOOD AUSTRALIA HOLDINGS PTY LTD**  
**C/- NIXANDERSON PTY LTD**  
**17 CHUTER STREET**  
**McMAHONS POINT NSW 2060**

**SURVEY PLAN**  
**SHOWING DETAIL & LEVELS**  
**OVER LOT 5 IN D.P.129325,**  
**LOT 398 & 399 IN D.P.752023**  
**AND LOT 2 IN D.P.230294**  
**160 BURWOOD ROAD**  
**CONCORD NSW 2137**

**C.M.S. Surveyors**  
**Pty Limited**

ACN: 096 240 201  
PO Box 463 Dee Why  
NSW 2099  
1/32 Campbell Avenue,  
Dee Why NSW 2099  
Telephone: (02) 9971 4802  
Facsimile: (02) 9971 4822  
E-mail: info@cmsurveyors.com.au

LGA: CANADA BAY	SHEET 2 OF 11		
SURVEYED MB	DRAWN CJR	CHECKED MB	APPROVED MJ
SURVEY INSTRUCTION 13040	SCALE 1:200 @ AI	DATE OF SURVEY 12/05/15	
DRAWING NAME 13040detail 3	CAD FILE 13040detail 3.dwg	ISSUE 1	

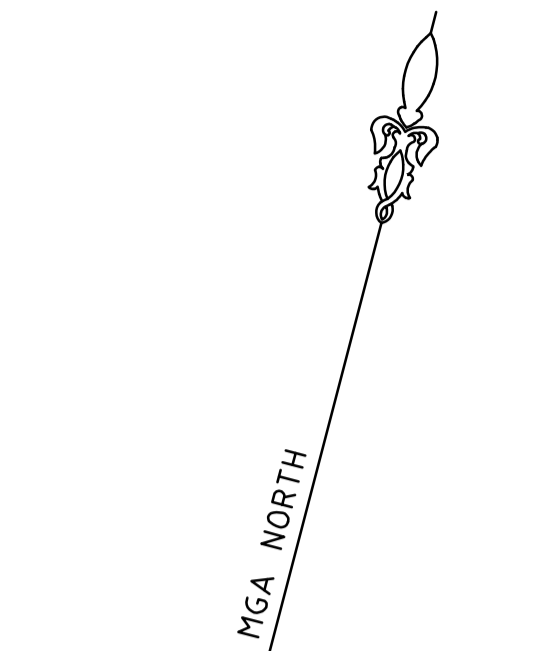

BRICK HOUSE TILE ROOF

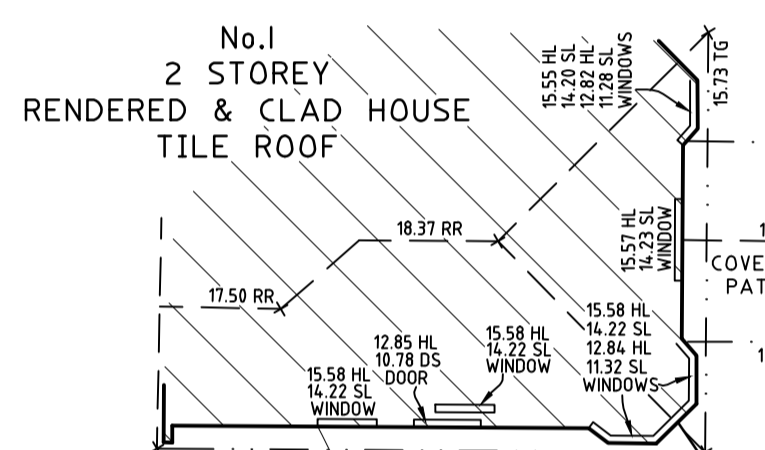
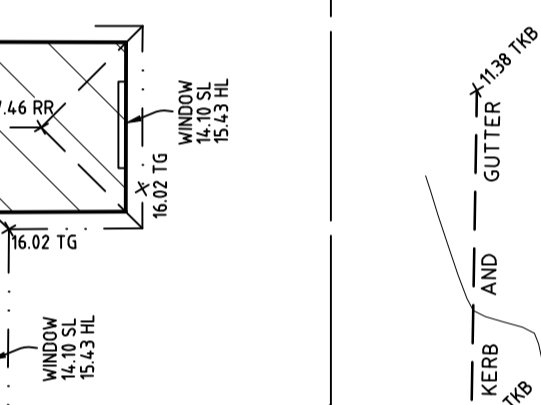

No.26 BRICK HOUSE TILE ROOF

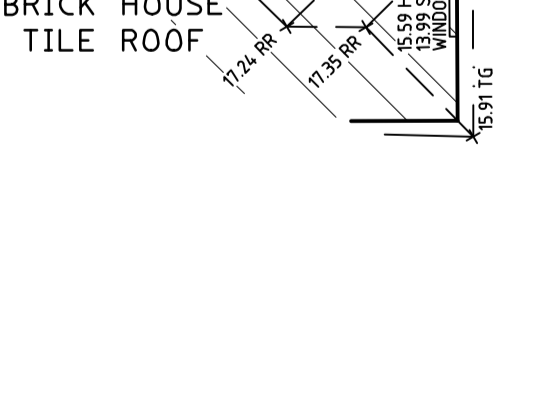

No.25 2 STOREY RENDERED HOUSE TILE ROOF

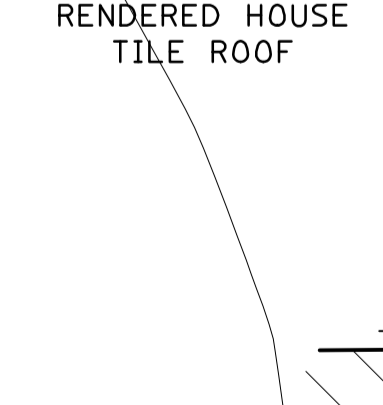

No.23 BRICK HOUSE TILE ROOF

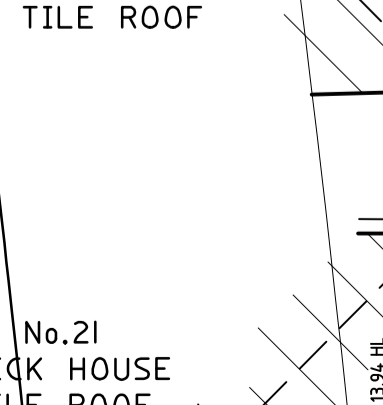

No.21 BRICK HOUSE TILE ROOF

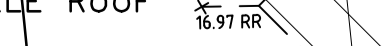

SHEET 4 ADJOINS

SHEET 3 ADJOINS

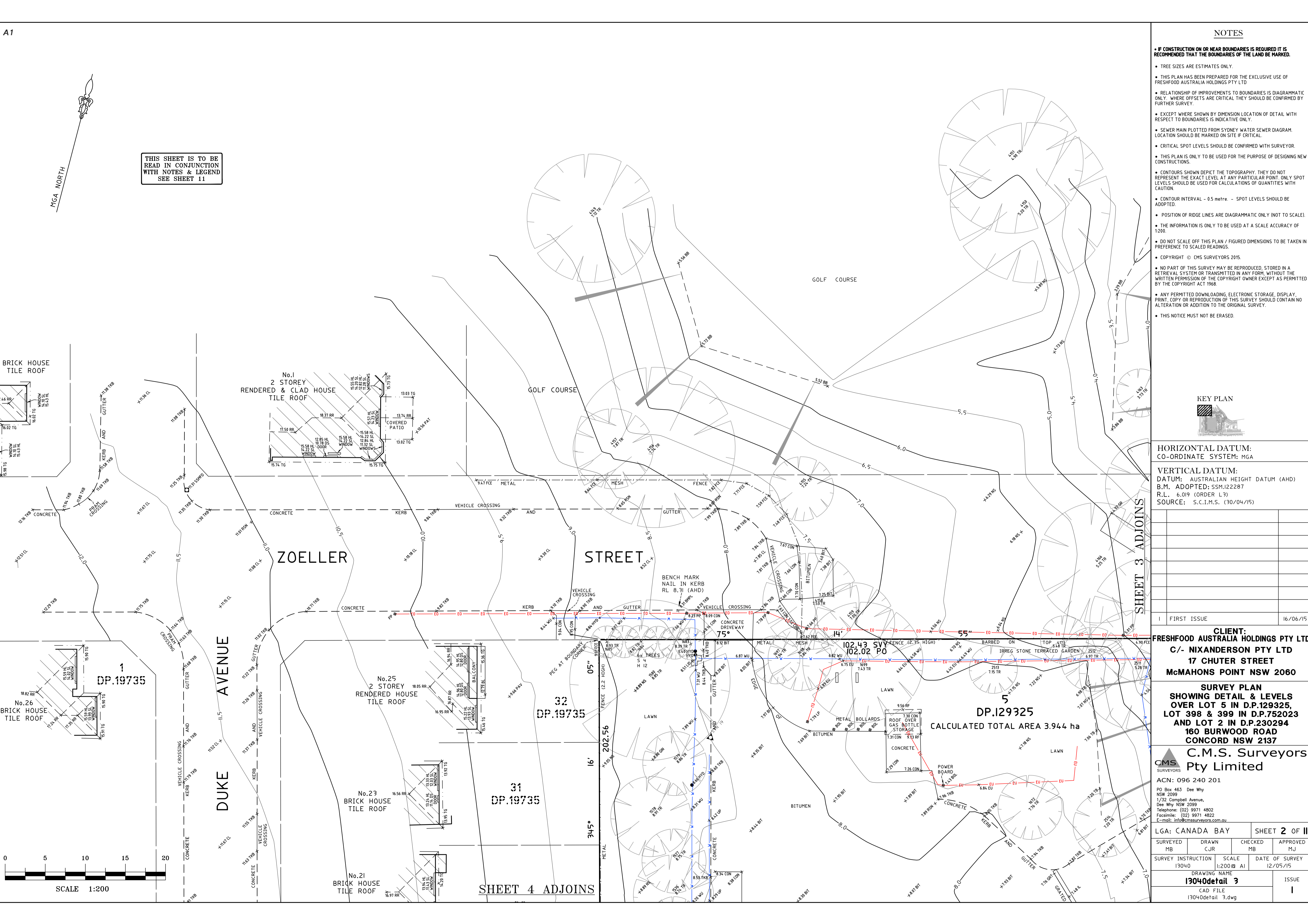



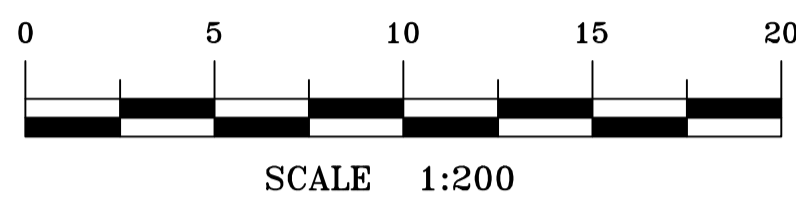
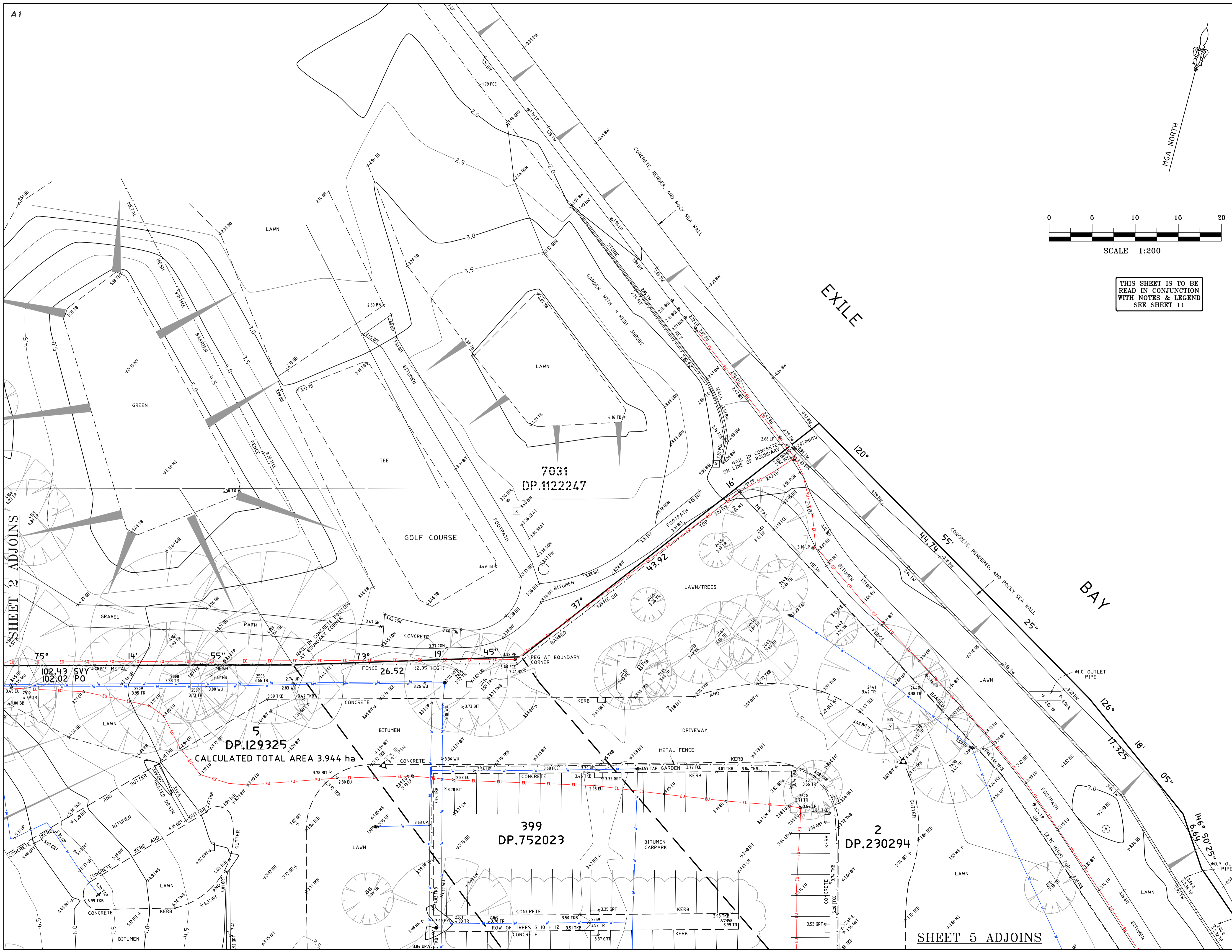

THIS SHEET IS TO BE READ IN CONJUNCTION WITH NOTES & LEGEND SEE SHEET 11

**NOTES**

- IF CONSTRUCTION ON OR NEAR BOUNDARIES IS REQUIRED IT IS RECOMMENDED THAT THE BOUNDARIES OF THE LAND BE MARKED.
- TREE SIZES ARE ESTIMATES ONLY.
- THIS PLAN HAS BEEN PREPARED FOR THE EXCLUSIVE USE OF FRESHFOOD AUSTRALIA HOLDINGS PTY LTD
- RELATIONSHIP OF IMPROVEMENTS TO BOUNDARIES IS DIAGRAMMATIC ONLY. WHERE OFFSETS ARE CRITICAL THEY SHOULD BE CONFIRMED BY FURTHER SURVEY.
- EXCEPT WHERE SHOWN BY DIMENSION LOCATION OF DETAIL WITH RESPECT TO BOUNDARIES IS INDICATIVE ONLY.
- SEWER MAIN PLOTTED FROM SYDNEY WATER SEWER DIAGRAM. LOCATION SHOULD BE MARKED ON SITE IF CRITICAL.
- CRITICAL SPOT LEVELS SHOULD BE CONFIRMED WITH SURVEYOR.
- THIS PLAN IS ONLY TO BE USED FOR THE PURPOSE OF DESIGNING NEW CONSTRUCTIONS.
- CONTOURS SHOWN DEPICT THE TOPOGRAPHY. THEY DO NOT REPRESENT THE EXACT LEVEL AT ANY PARTICULAR POINT. ONLY SPOT LEVELS SHOULD BE USED FOR CALCULATIONS OF QUANTITIES WITH CAUTION.
- CONTOUR INTERVAL - 0.5 metre. - SPOT LEVELS SHOULD BE ADOPTED.
- POSITION OF RIDGE LINES ARE DIAGRAMMATIC ONLY (NOT TO SCALE).
- THE INFORMATION IS ONLY TO BE USED AT A SCALE ACCURACY OF 1:200.
- DO NOT SCALE OFF THIS PLAN / FIGURED DIMENSIONS TO BE TAKEN IN PREFERENCE TO SCALED READINGS.
- COPYRIGHT © CMS SURVEYORS 2015.
- NO PART OF THIS SURVEY MAY BE REPRODUCED, STORED IN A RETRIEVAL SYSTEM OR TRANSMITTED IN ANY FORM, WITHOUT THE WRITTEN PERMISSION OF THE COPYRIGHT OWNER EXCEPT AS PERMITTED BY THE COPYRIGHT ACT 1968.
- ANY PERMITTED DOWNLOADING, ELECTRONIC STORAGE, DISPLAY, PRINT, COPY OR REPRODUCTION OF THIS SURVEY SHOULD CONTAIN NO ALTERATION OR ADDITION TO THE ORIGINAL SURVEY.
- THIS NOTICE MUST NOT BE ERASED.

**KEY PLAN**

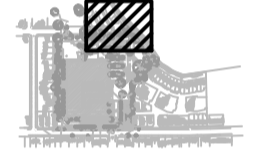

**HORIZONTAL DATUM:**  
CO-ORDINATE SYSTEM: MGA

**VERTICAL DATUM:**  
DATUM: AUSTRALIAN HEIGHT DATUM (AHD)  
B.M. ADOPTED: SSM.122287  
R.L. 6.019 (ORDER L3)  
SOURCE: S.C.I.M.S. (30/04/15)

FIRST ISSUE 16/06/15

**CLIENT:**  
FRESHFOOD AUSTRALIA HOLDINGS PTY LTD  
C/- NIXANDERSON PTY LTD  
17 CHUTER STREET  
McMAHONS POINT NSW 2060

**SURVEY PLAN**  
SHOWING DETAIL & LEVELS  
OVER LOT 5 IN D.P.129325,  
LOT 398 & 399 IN D.P.752023  
AND LOT 2 IN D.P.230294  
160 BURWOOD ROAD  
CONCORD NSW 2137

**C.M.S. Surveyors Pty Limited**

ACN: 096 240 201  
PO Box 463 Dee Why NSW 2099  
1/32 Campbell Avenue, Dee Why NSW 2099  
Telephone: (02) 9971 4802  
Facsimile: (02) 9971 4822  
E-mail: info@cmsurveyors.com.au

LGA: CANADA BAY		SHEET 3 OF 11	
SURVEYED MB	DRAWN CJR	CHECKED MB	APPROVED MJ
SURVEY INSTRUCTION 13040	SCALE 1:200	DATE OF SURVEY 12/05/15	
DRAWING NAME 13040detail 3		ISSUE 1	
CAD FILE 13040detail 3.dwg			

SHEET 2 ADJOINS

SHEET 5 ADJOINS



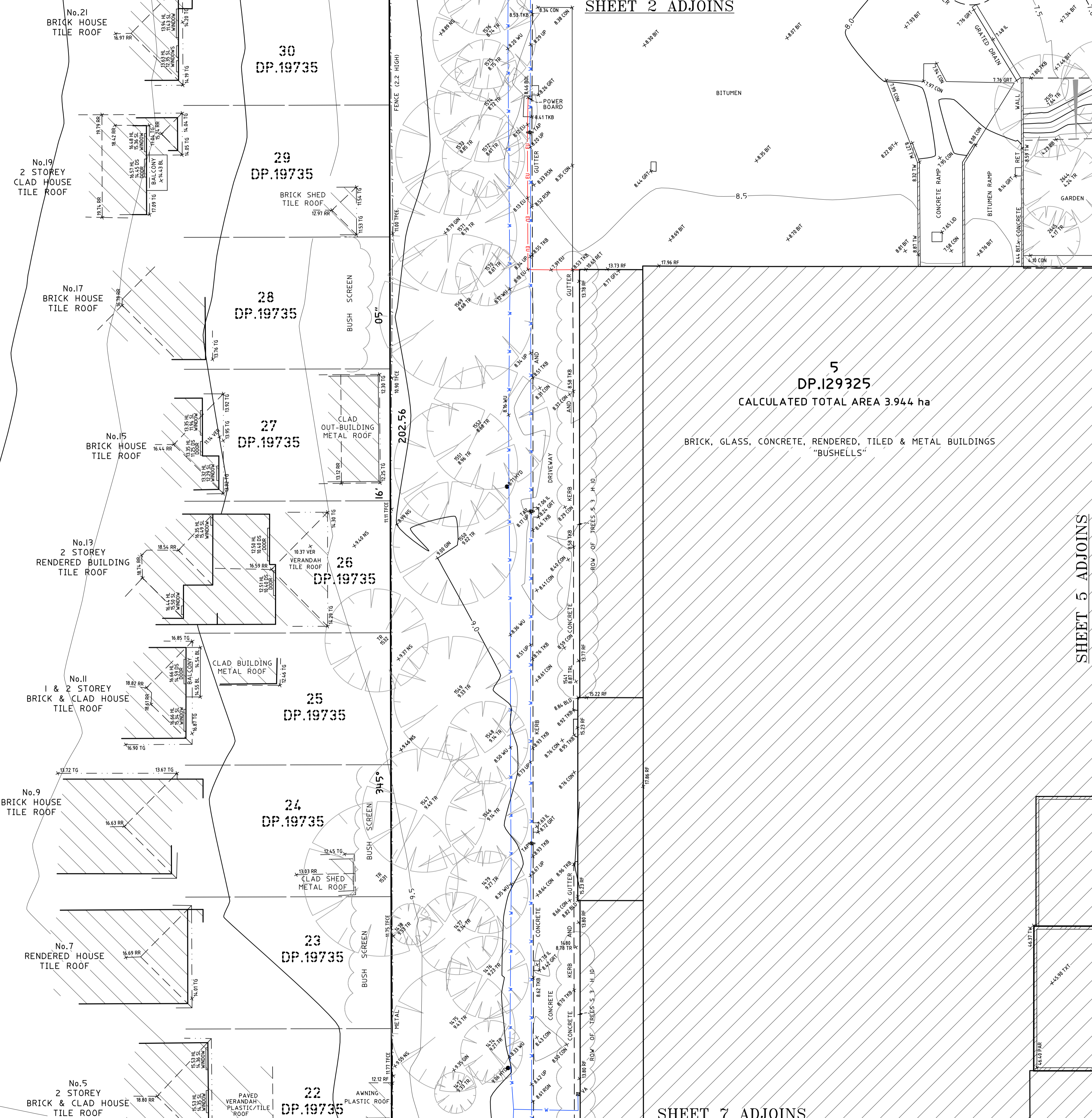
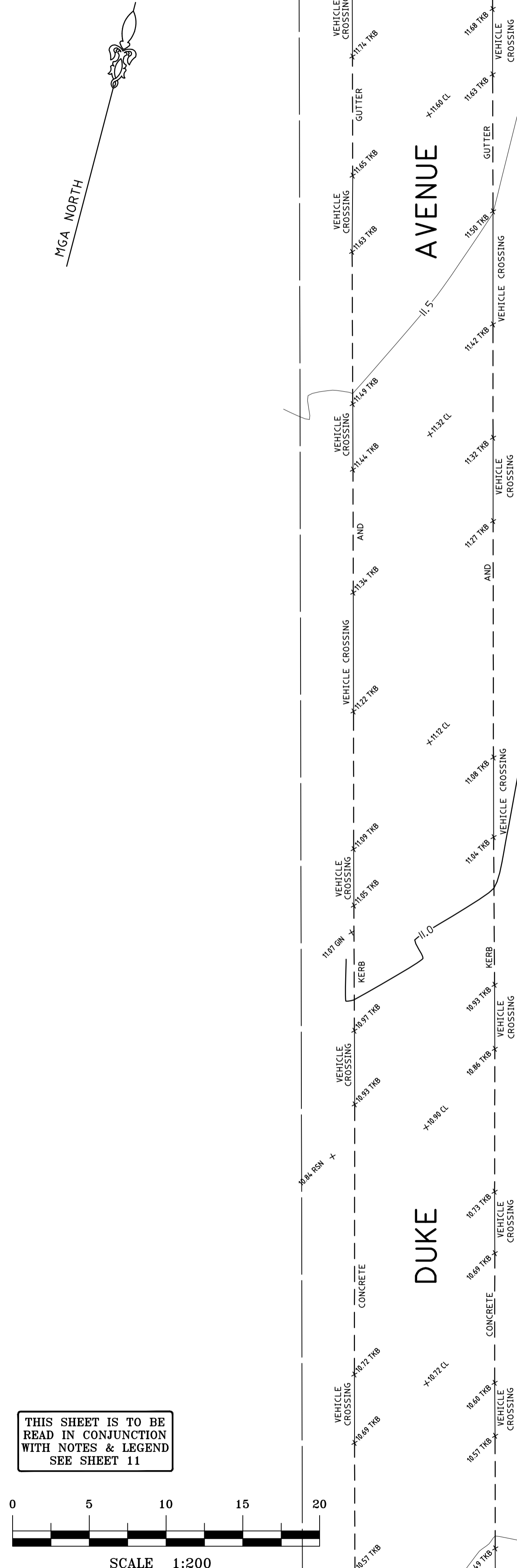

- NOTES**
- IF CONSTRUCTION ON OR NEAR BOUNDARIES IS REQUIRED IT IS RECOMMENDED THAT THE BOUNDARIES OF THE LAND BE MARKED.
  - TREE SIZES ARE ESTIMATES ONLY.
  - THIS PLAN HAS BEEN PREPARED FOR THE EXCLUSIVE USE OF FRESHFOOD AUSTRALIA HOLDINGS PTY LTD
  - RELATIONSHIP OF IMPROVEMENTS TO BOUNDARIES IS DIAGRAMMATIC ONLY. WHERE OFFSETS ARE CRITICAL THEY SHOULD BE CONFIRMED BY FURTHER SURVEY.
  - EXCEPT WHERE SHOWN BY DIMENSION LOCATION OF DETAIL WITH RESPECT TO BOUNDARIES IS INDICATIVE ONLY.
  - SEWER MAIN PLOTTED FROM SYDNEY WATER SEWER DIAGRAM. LOCATION SHOULD BE MARKED ON SITE IF CRITICAL.
  - CRITICAL SPOT LEVELS SHOULD BE CONFIRMED WITH SURVEYOR.
  - THIS PLAN IS ONLY TO BE USED FOR THE PURPOSE OF DESIGNING NEW CONSTRUCTIONS.
  - CONTOURS SHOWN DEPICT THE TOPOGRAPHY. THEY DO NOT REPRESENT THE EXACT LEVEL AT ANY PARTICULAR POINT. ONLY SPOT LEVELS SHOULD BE USED FOR CALCULATIONS OF QUANTITIES WITH CAUTION.
  - CONTOUR INTERVAL - 0.5 metre. - SPOT LEVELS SHOULD BE ADOPTED.
  - POSITION OF RIDGE LINES ARE DIAGRAMMATIC ONLY (NOT TO SCALE).
  - THE INFORMATION IS ONLY TO BE USED AT A SCALE ACCURACY OF 1:200.
  - DO NOT SCALE OFF THIS PLAN / FIGURED DIMENSIONS TO BE TAKEN IN PREFERENCE TO SCALED READINGS.
  - COPYRIGHT © CMS SURVEYORS 2015.
  - NO PART OF THIS SURVEY MAY BE REPRODUCED, STORED IN A RETRIEVAL SYSTEM OR TRANSMITTED IN ANY FORM, WITHOUT THE WRITTEN PERMISSION OF THE COPYRIGHT OWNER EXCEPT AS PERMITTED BY THE COPYRIGHT ACT 1968.
  - ANY PERMITTED DOWNLOADING, ELECTRONIC STORAGE, DISPLAY, PRINT, COPY OR REPRODUCTION OF THIS SURVEY SHOULD CONTAIN NO ALTERATION OR ADDITION TO THE ORIGINAL SURVEY.
  - THIS NOTICE MUST NOT BE ERASED.

**KEY PLAN**

**HORIZONTAL DATUM:**  
CO-ORDINATE SYSTEM: MGA

**VERTICAL DATUM:**  
DATUM: AUSTRALIAN HEIGHT DATUM (AHD)  
B.M. ADOPTED: SSM.122287  
R.L. 6.019 (ORDER L3)  
SOURCE: S.C.I.M.S. (30/04/15)

1	FIRST ISSUE	16/06/15
---	-------------	----------

**CLIENT:**  
FRESHFOOD AUSTRALIA HOLDINGS PTY LTD  
C/- NIXANDERSON PTY LTD  
17 CHUTER STREET  
McMAHONS POINT NSW 2060

**SURVEY PLAN**  
SHOWING DETAIL & LEVELS  
OVER LOT 5 IN D.P.129325,  
LOT 398 & 399 IN D.P.752023  
AND LOT 2 IN D.P.230294  
160 BURWOOD ROAD  
CONCORD NSW 2137

**C.M.S. Surveyors Pty Limited**  
ACN: 096 240 201  
PO Box 463 Dee Why NSW 2099  
1/32 Campbell Avenue, Dee Why NSW 2099  
Telephone: (02) 9971 4802  
Facsimile: (02) 9971 4822  
E-mail: info@cmsurveyors.com.au

LGA: CANADA BAY SHEET 4 OF 11

SURVEYED MB	DRAWN CJR	CHECKED MB	APPROVED MJ
-------------	-----------	------------	-------------

SURVEY INSTRUCTION 13040 SCALE 1:200 @ A1 DATE OF SURVEY 12/05/15

DRAWING NAME 13040detail 3 ISSUE 1

CAD FILE 13040detail 3.dwg

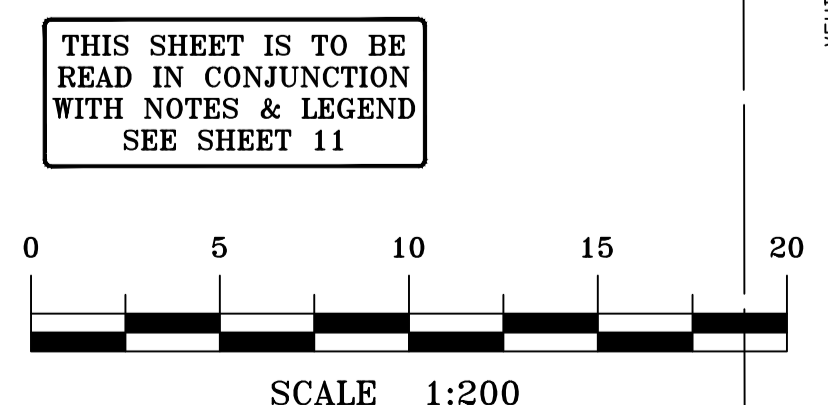

THIS SHEET IS TO BE READ IN CONJUNCTION WITH NOTES & LEGEND SEE SHEET 11



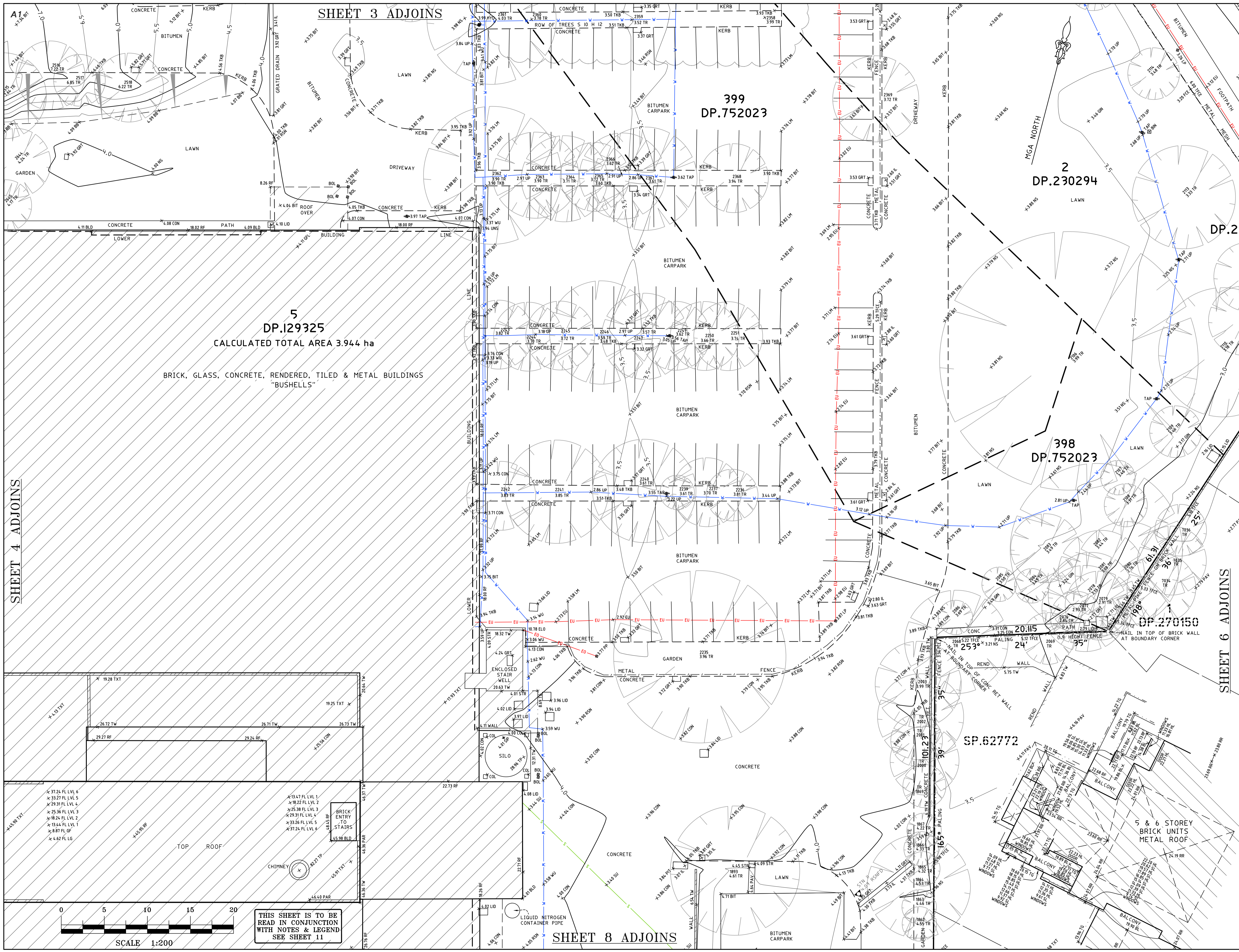

SHEET 3 ADJOINS

SHEET 4 ADJOINS

SHEET 6 ADJOINS

SHEET 8 ADJOINS

THIS SHEET IS TO BE READ IN CONJUNCTION WITH NOTES & LEGEND SEE SHEET 11

NOTES

- IF CONSTRUCTION ON OR NEAR BOUNDARIES IS REQUIRED IT IS RECOMMENDED THAT THE BOUNDARIES OF THE LAND BE MARKED.
- TREE SIZES ARE ESTIMATES ONLY.
- THIS PLAN HAS BEEN PREPARED FOR THE EXCLUSIVE USE OF FRESHFOOD AUSTRALIA HOLDINGS PTY LTD
- RELATIONSHIP OF IMPROVEMENTS TO BOUNDARIES IS DIAGRAMMATIC ONLY. WHERE OFFSETS ARE CRITICAL THEY SHOULD BE CONFIRMED BY FURTHER SURVEY.
- EXCEPT WHERE SHOWN BY DIMENSION LOCATION OF DETAIL WITH RESPECT TO BOUNDARIES IS INDICATIVE ONLY.
- SEWER MAIN PLOTTED FROM SYDNEY WATER SEWER DIAGRAM. LOCATION SHOULD BE MARKED ON SITE IF CRITICAL.
- CRITICAL SPOT LEVELS SHOULD BE CONFIRMED WITH SURVEYOR.
- THIS PLAN IS ONLY TO BE USED FOR THE PURPOSE OF DESIGNING NEW CONSTRUCTIONS.
- CONTOURS SHOWN DEPICT THE TOPOGRAPHY. THEY DO NOT REPRESENT THE EXACT LEVEL AT ANY PARTICULAR POINT. ONLY SPOT LEVELS SHOULD BE USED FOR CALCULATIONS OF QUANTITIES WITH CAUTION.
- CONTOUR INTERVAL - 0.5 metre - SPOT LEVELS SHOULD BE ADOPTED.
- POSITION OF RIDGE LINES ARE DIAGRAMMATIC ONLY (NOT TO SCALE).
- THE INFORMATION IS ONLY TO BE USED AT A SCALE ACCURACY OF 1:200.
- DO NOT SCALE OFF THIS PLAN / FIGURED DIMENSIONS TO BE TAKEN IN PREFERENCE TO SCALED READINGS.
- COPYRIGHT © CMS SURVEYORS 2015.
- NO PART OF THIS SURVEY MAY BE REPRODUCED, STORED IN A RETRIEVAL SYSTEM OR TRANSMITTED IN ANY FORM, WITHOUT THE WRITTEN PERMISSION OF THE COPYRIGHT OWNER EXCEPT AS PERMITTED BY THE COPYRIGHT ACT 1968.
- ANY PERMITTED DOWNLOADING, ELECTRONIC STORAGE, DISPLAY, PRINT, COPY OR REPRODUCTION OF THIS SURVEY SHOULD CONTAIN NO ALTERATION OR ADDITION TO THE ORIGINAL SURVEY.
- THIS NOTICE MUST NOT BE ERASED.

KEY PLAN

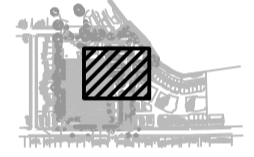

HORIZONTAL DATUM:  
CO-ORDINATE SYSTEM: MGA

VERTICAL DATUM:  
DATUM: AUSTRALIAN HEIGHT DATUM (AHD)  
B.M. ADOPTED: SSM122287  
R.L. 6.019 (ORDER L3)  
SOURCE: S.C.I.M.S. (30/04/15)

1 FIRST ISSUE 16/06/15

CLIENT:  
**FRESHFOOD AUSTRALIA HOLDINGS PTY LTD**  
C/- NIXANDERSON PTY LTD  
17 CHUTER STREET  
McMAHONS POINT NSW 2060

SURVEY PLAN  
SHOWING DETAIL & LEVELS  
OVER LOT 5 IN D.P.129325,  
LOT 398 & 399 IN D.P.752023  
AND LOT 2 IN D.P.230294  
160 BURWOOD ROAD  
CONCORD NSW 2137

**C.M.S. Surveyors Pty Limited**

ACN: 096 240 201  
PO Box 463 Dee Why  
NSW 2099  
1/32 Campbell Avenue,  
Dee Why NSW 2099  
Telephone: (02) 9971 4802  
Facsimile: (02) 9971 4822  
E-mail: info@cmsurveyors.com.au

LGA: CANADA BAY		SHEET 5 OF 11	
SURVEYED MB	DRAWN CJR	CHECKED MB	APPROVED MJ
SURVEY INSTRUCTION 13040		SCALE 1:200 @ AI	DATE OF SURVEY 12/05/15
DRAWING NAME 13040detail 3		ISSUE 1	
CAD FILE 13040detail 3.dwg			



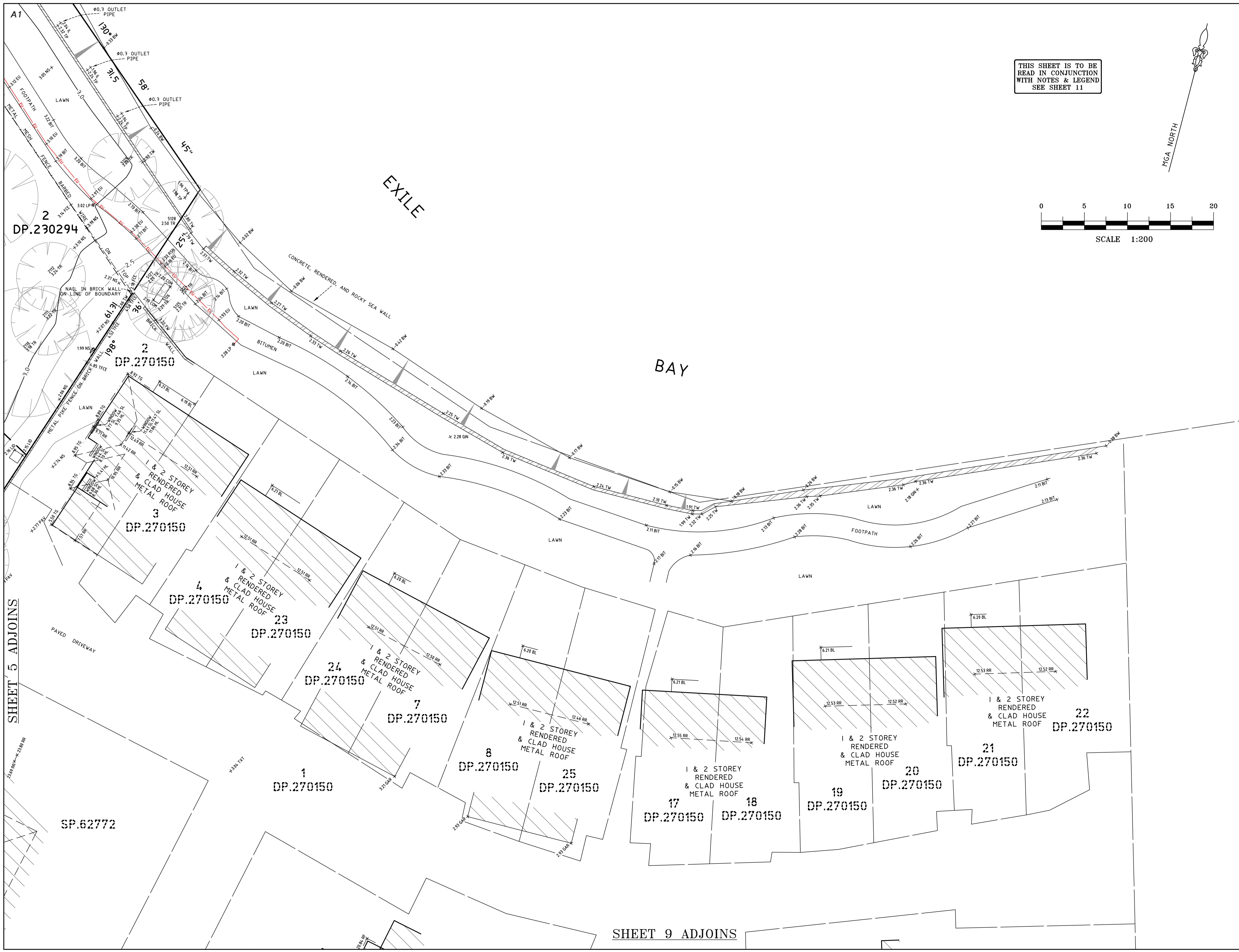

THIS SHEET IS TO BE READ IN CONJUNCTION WITH NOTES & LEGEND SEE SHEET 11

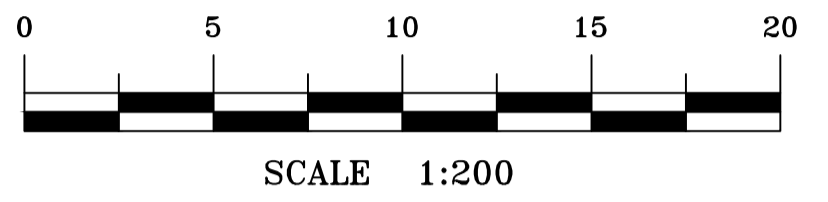
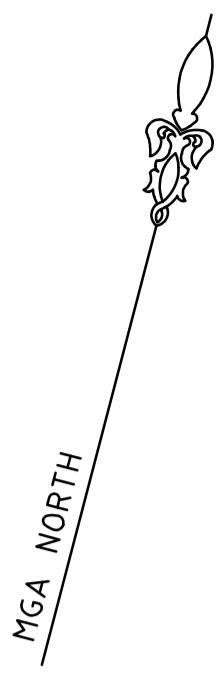

**NOTES**

- IF CONSTRUCTION OR NEAR BOUNDARIES IS REQUIRED IT IS RECOMMENDED THAT THE BOUNDARIES OF THE LAND BE MARKED.
- TREE SIZES ARE ESTIMATES ONLY.
- THIS PLAN HAS BEEN PREPARED FOR THE EXCLUSIVE USE OF FRESHFOOD AUSTRALIA HOLDINGS PTY LTD
- RELATIONSHIP OF IMPROVEMENTS TO BOUNDARIES IS DIAGRAMMATIC ONLY. WHERE OFFSETS ARE CRITICAL THEY SHOULD BE CONFIRMED BY FURTHER SURVEY.
- EXCEPT WHERE SHOWN BY DIMENSION LOCATION OF DETAIL WITH RESPECT TO BOUNDARIES IS INDICATIVE ONLY.
- SEWER MAIN PLOTTED FROM SYDNEY WATER SEWER DIAGRAM. LOCATION SHOULD BE MARKED ON SITE IF CRITICAL.
- CRITICAL SPOT LEVELS SHOULD BE CONFIRMED WITH SURVEYOR.
- THIS PLAN IS ONLY TO BE USED FOR THE PURPOSE OF DESIGNING NEW CONSTRUCTIONS.
- CONTOURS SHOWN DEPICT THE TOPOGRAPHY. THEY DO NOT REPRESENT THE EXACT LEVEL AT ANY PARTICULAR POINT. ONLY SPOT LEVELS SHOULD BE USED FOR CALCULATIONS OF QUANTITIES WITH CAUTION.
- CONTOUR INTERVAL - 0.5 metre. - SPOT LEVELS SHOULD BE ADOPTED.
- POSITION OF RIDGE LINES ARE DIAGRAMMATIC ONLY (NOT TO SCALE).
- THE INFORMATION IS ONLY TO BE USED AT A SCALE ACCURACY OF 1:200.
- DO NOT SCALE OFF THIS PLAN / FIGURED DIMENSIONS TO BE TAKEN IN PREFERENCE TO SCALED READINGS.
- COPYRIGHT © CMS SURVEYORS 2015.
- NO PART OF THIS SURVEY MAY BE REPRODUCED, STORED IN A RETRIEVAL SYSTEM OR TRANSMITTED IN ANY FORM, WITHOUT THE WRITTEN PERMISSION OF THE COPYRIGHT OWNER EXCEPT AS PERMITTED BY THE COPYRIGHT ACT 1968.
- ANY PERMITTED DOWNLOADING, ELECTRONIC STORAGE, DISPLAY, PRINT, COPY OR REPRODUCTION OF THIS SURVEY SHOULD CONTAIN NO ALTERATION OR ADDITION TO THE ORIGINAL SURVEY.
- THIS NOTICE MUST NOT BE ERASED.

**KEY PLAN**

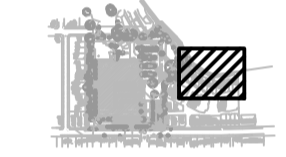

HORIZONTAL DATUM:  
CO-ORDINATE SYSTEM: MGA

VERTICAL DATUM:  
DATUM: AUSTRALIAN HEIGHT DATUM (AHD)  
B.M. ADOPTED: SSM.122287  
R.L. 6.019 (ORDER L3)  
SOURCE: S.C.I.M.S. (30/04/15)

1	FIRST ISSUE	16/06/15
---	-------------	----------

**CLIENT:**  
FRESHFOOD AUSTRALIA HOLDINGS PTY LTD  
C/- NIXANDERSON PTY LTD  
17 CHUTER STREET  
McMAHONS POINT NSW 2060

**SURVEY PLAN**  
**SHOWING DETAIL & LEVELS**  
**OVER LOT 5 IN D.P.129325,**  
**LOT 398 & 399 IN D.P.752023**  
**AND LOT 2 IN D.P.230294**  
**160 BURWOOD ROAD**  
**CONCORD NSW 2137**

**C.M.S. Surveyors**  
**Pty Limited**

ACN: 096 240 201  
PO Box 463 Dee Why  
NSW 2099  
1/32 Campbell Avenue,  
Dee Why NSW 2099  
Telephone: (02) 9971 4802  
Facsimile: (02) 9971 4822  
E-mail: info@cmsurveyors.com.au

LGA: CANADA BAY		SHEET 6 OF 11	
SURVEYED MB	DRAWN CJR	CHECKED MB	APPROVED MJ
SURVEY INSTRUCTION 13040	SCALE 1:200 @ AI	DATE OF SURVEY 12/05/15	
DRAWING NAME <b>13040detail 3</b>			ISSUE <b>1</b>
CAD FILE 13040detail 3.dwg			

SHEET 9 ADJOINS











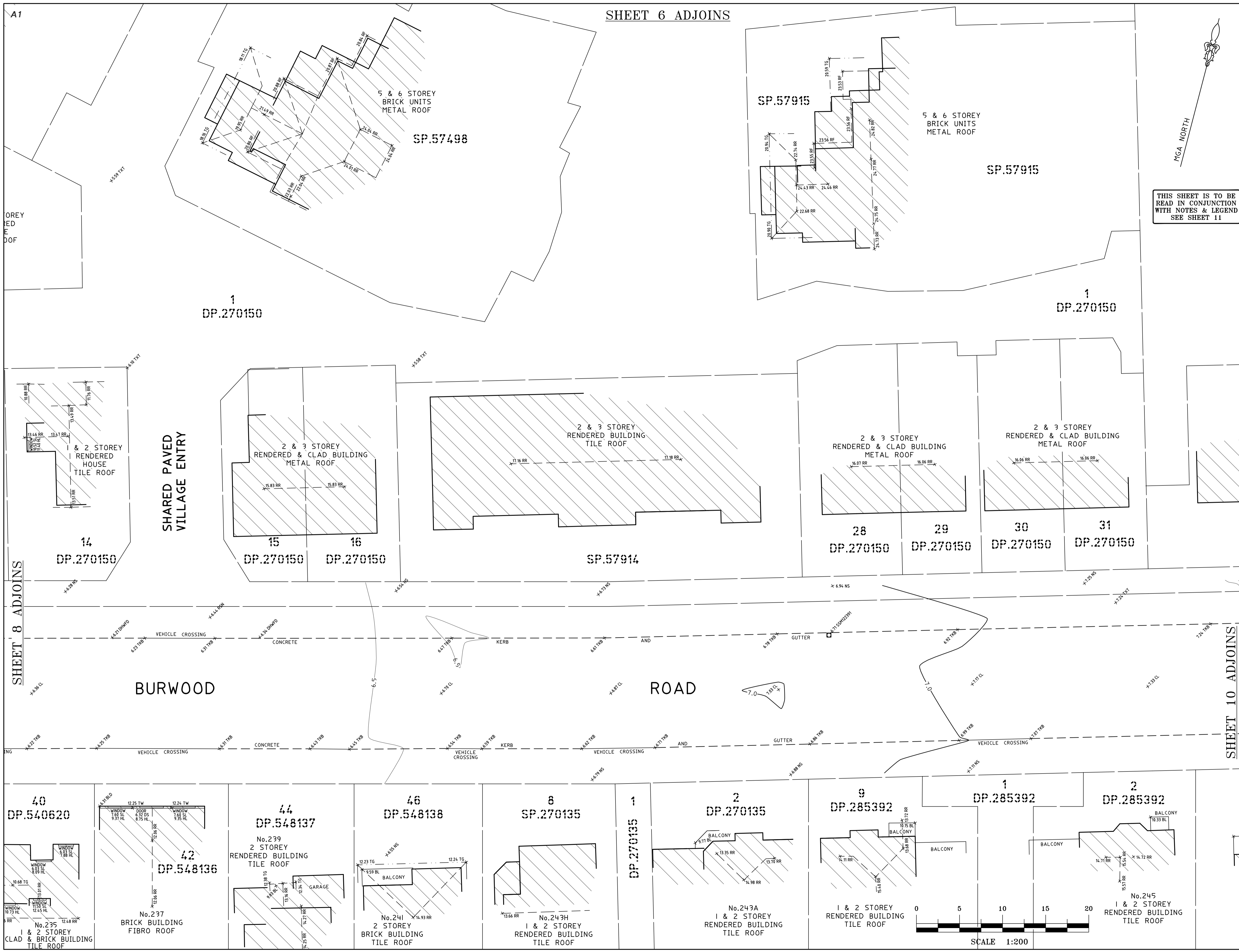

SHEET 6 ADJOINS

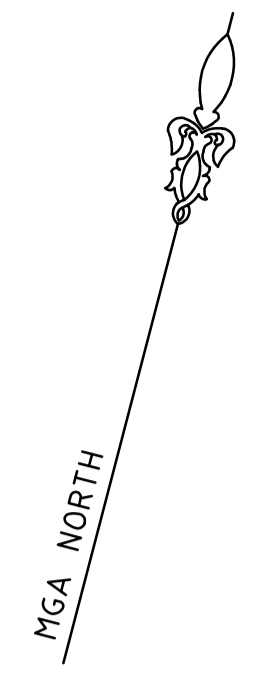

THIS SHEET IS TO BE READ IN CONJUNCTION WITH NOTES & LEGEND SEE SHEET 11

NOTES

- IF CONSTRUCTION OR NEAR BOUNDARIES IS REQUIRED IT IS RECOMMENDED THAT THE BOUNDARIES OF THE LAND BE MARKED.
- TREE SIZES ARE ESTIMATES ONLY.
- THIS PLAN HAS BEEN PREPARED FOR THE EXCLUSIVE USE OF FRESHFOOD AUSTRALIA HOLDINGS PTY LTD
- RELATIONSHIP OF IMPROVEMENTS TO BOUNDARIES IS DIAGRAMMATIC ONLY. WHERE OFFSETS ARE CRITICAL THEY SHOULD BE CONFIRMED BY FURTHER SURVEY.
- EXCEPT WHERE SHOWN BY DIMENSION LOCATION OF DETAIL WITH RESPECT TO BOUNDARIES IS INDICATIVE ONLY.
- SEWER MAIN PLOTTED FROM SYDNEY WATER SEWER DIAGRAM. LOCATION SHOULD BE MARKED ON SITE IF CRITICAL.
- CRITICAL SPOT LEVELS SHOULD BE CONFIRMED WITH SURVEYOR.
- THIS PLAN IS ONLY TO BE USED FOR THE PURPOSE OF DESIGNING NEW CONSTRUCTIONS.
- CONTOURS SHOWN DEPICT THE TOPOGRAPHY. THEY DO NOT REPRESENT THE EXACT LEVEL AT ANY PARTICULAR POINT. ONLY SPOT LEVELS SHOULD BE USED FOR CALCULATIONS OF QUANTITIES WITH CAUTION.
- CONTOUR INTERVAL - 0.5 metre - SPOT LEVELS SHOULD BE ADOPTED.
- POSITION OF RIDGE LINES ARE DIAGRAMMATIC ONLY (NOT TO SCALE).
- THE INFORMATION IS ONLY TO BE USED AT A SCALE ACCURACY OF 1:200.
- DO NOT SCALE OFF THIS PLAN / FIGURED DIMENSIONS TO BE TAKEN IN PREFERENCE TO SCALED READINGS.
- COPYRIGHT © CMS SURVEYORS 2015.
- NO PART OF THIS SURVEY MAY BE REPRODUCED, STORED IN A RETRIEVAL SYSTEM OR TRANSMITTED IN ANY FORM, WITHOUT THE WRITTEN PERMISSION OF THE COPYRIGHT OWNER EXCEPT AS PERMITTED BY THE COPYRIGHT ACT 1968.
- ANY PERMITTED DOWNLOADING, ELECTRONIC STORAGE, DISPLAY, PRINT, COPY OR REPRODUCTION OF THIS SURVEY SHOULD CONTAIN NO ALTERATION OR ADDITION TO THE ORIGINAL SURVEY.
- THIS NOTICE MUST NOT BE ERASED.

KEY PLAN

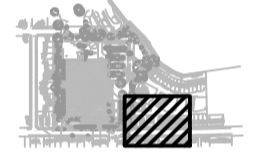

HORIZONTAL DATUM:  
CO-ORDINATE SYSTEM: MGA

VERTICAL DATUM:  
DATUM: AUSTRALIAN HEIGHT DATUM (AHD)  
B.M. ADOPTED: SSM.122287  
R.L. 6.019 (ORDER L3)  
SOURCE: S.C.I.M.S. (30/04/15)

I FIRST ISSUE 16/06/15

CLIENT:  
**FRESHFOOD AUSTRALIA HOLDINGS PTY LTD**  
**C/- NIXANDERSON PTY LTD**  
**17 CHUTER STREET**  
**McMAHONS POINT NSW 2060**

SURVEY PLAN  
SHOWING DETAIL & LEVELS  
OVER LOT 5 IN D.P.129325,  
LOT 398 & 399 IN D.P.752023  
AND LOT 2 IN D.P.230294  
**160 BURWOOD ROAD**  
**CONCORD NSW 2137**

**C.M.S. Surveyors**  
**Pty Limited**

ACN: 096 240 201  
PO Box 463 Dee Why  
NSW 2099  
1/32 Campbell Avenue,  
Dee Why NSW 2099  
Telephone: (02) 9971 4802  
Facsimile: (02) 9971 4822  
E-mail: info@cmsurveyors.com.au

LGA: CANADA BAY		SHEET 9 OF 11	
SURVEYED MB	DRAWN CJR	CHECKED MB	APPROVED MJ
SURVEY INSTRUCTION 13040		SCALE 1:200 @ AI	DATE OF SURVEY 12/05/15
DRAWING NAME <b>13040detail 3</b>			ISSUE <b>1</b>
CAD FILE 13040detail 3.dwg			

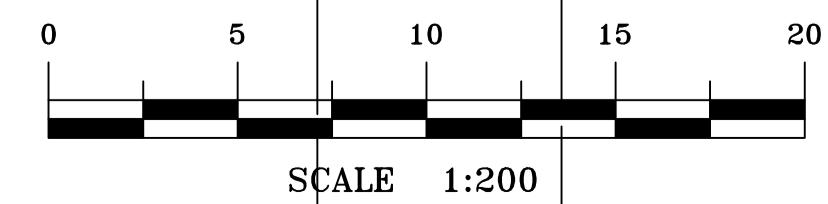



SHEET 6 ADJOINS

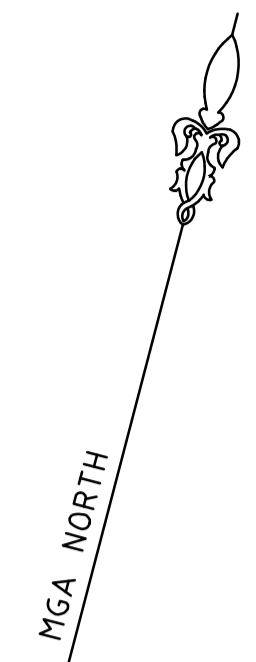
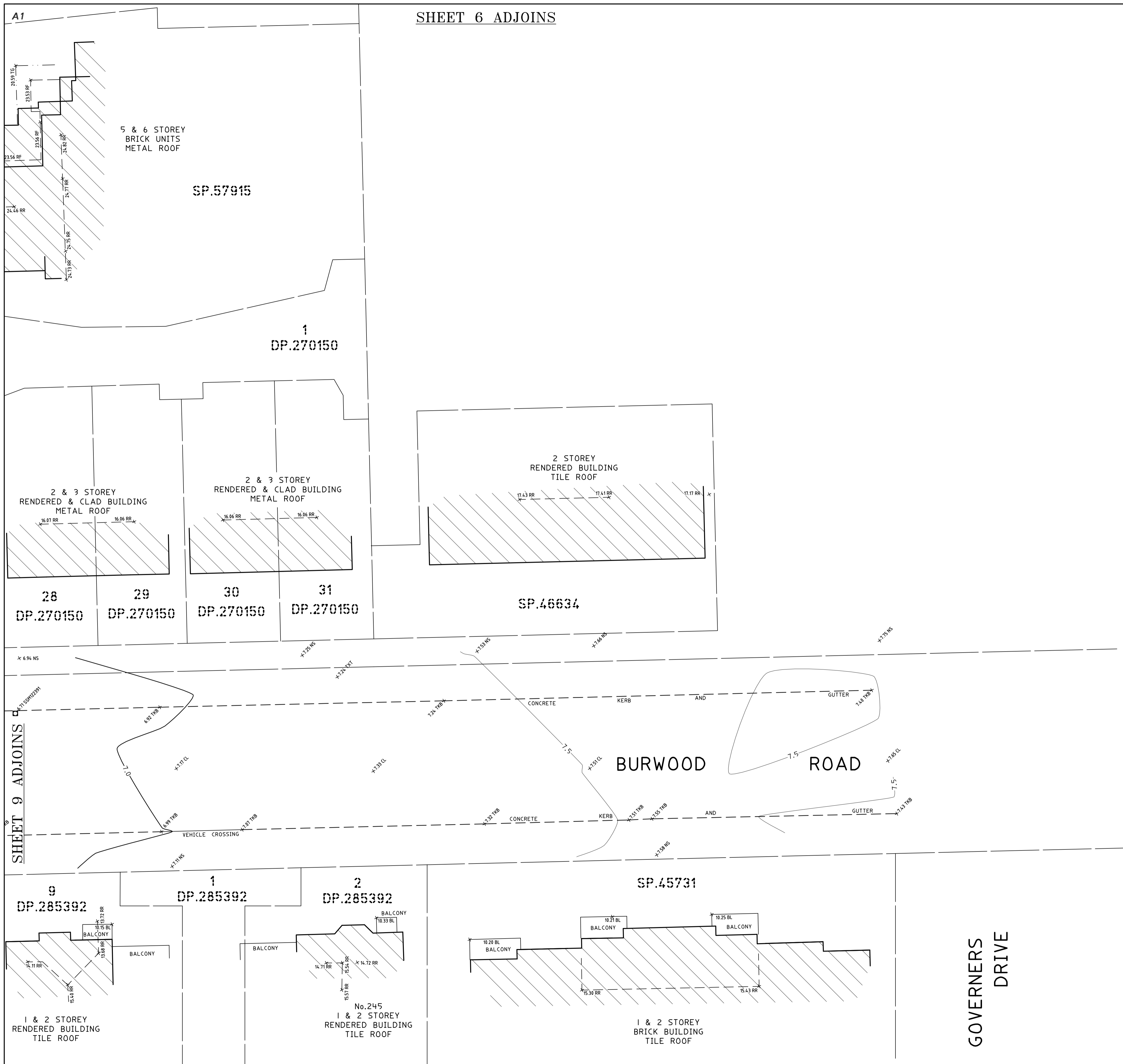

NOTES

- IF CONSTRUCTION ON OR NEAR BOUNDARIES IS REQUIRED IT IS RECOMMENDED THAT THE BOUNDARIES OF THE LAND BE MARKED.
- TREE SIZES ARE ESTIMATES ONLY.
- THIS PLAN HAS BEEN PREPARED FOR THE EXCLUSIVE USE OF FRESHFOOD AUSTRALIA HOLDINGS PTY LTD
- RELATIONSHIP OF IMPROVEMENTS TO BOUNDARIES IS DIAGRAMMATIC ONLY. WHERE OFFSETS ARE CRITICAL THEY SHOULD BE CONFIRMED BY FURTHER SURVEY.
- EXCEPT WHERE SHOWN BY DIMENSION LOCATION OF DETAIL WITH RESPECT TO BOUNDARIES IS INDICATIVE ONLY.
- SEWER MAIN PLOTTED FROM SYDNEY WATER SEWER DIAGRAM. LOCATION SHOULD BE MARKED ON SITE IF CRITICAL.
- CRITICAL SPOT LEVELS SHOULD BE CONFIRMED WITH SURVEYOR.
- THIS PLAN IS ONLY TO BE USED FOR THE PURPOSE OF DESIGNING NEW CONSTRUCTIONS.
- CONTOURS SHOWN DEPICT THE TOPOGRAPHY. THEY DO NOT REPRESENT THE EXACT LEVEL AT ANY PARTICULAR POINT. ONLY SPOT LEVELS SHOULD BE USED FOR CALCULATIONS OF QUANTITIES WITH CAUTION.
- CONTOUR INTERVAL - 0.5 metre. - SPOT LEVELS SHOULD BE ADOPTED.
- POSITION OF RIDGE LINES ARE DIAGRAMMATIC ONLY (NOT TO SCALE).
- THE INFORMATION IS ONLY TO BE USED AT A SCALE ACCURACY OF 1:200.
- DO NOT SCALE OFF THIS PLAN / FIGURED DIMENSIONS TO BE TAKEN IN PREFERENCE TO SCALED READINGS.
- COPYRIGHT © CMS SURVEYORS 2015.
- NO PART OF THIS SURVEY MAY BE REPRODUCED, STORED IN A RETRIEVAL SYSTEM OR TRANSMITTED IN ANY FORM, WITHOUT THE WRITTEN PERMISSION OF THE COPYRIGHT OWNER EXCEPT AS PERMITTED BY THE COPYRIGHT ACT 1968.
- ANY PERMITTED DOWNLOADING, ELECTRONIC STORAGE, DISPLAY, PRINT, COPY OR REPRODUCTION OF THIS SURVEY SHOULD CONTAIN NO ALTERATION OR ADDITION TO THE ORIGINAL SURVEY.
- THIS NOTICE MUST NOT BE ERASED.

KEY PLAN

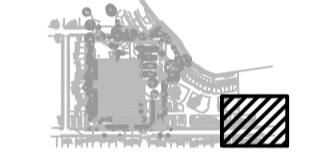

HORIZONTAL DATUM:  
CO-ORDINATE SYSTEM: MGA

VERTICAL DATUM:  
DATUM: AUSTRALIAN HEIGHT DATUM (AHD)  
B.M. ADOPTED: SSM.122287  
R.L. 6.019 (ORDER L3)  
SOURCE: S.C.I.M.S. (30/04/15)

1	FIRST ISSUE	16/06/15
---	-------------	----------

CLIENT:  
FRESHFOOD AUSTRALIA HOLDINGS PTY LTD  
C/- NIXANDERSON PTY LTD  
17 CHUTER STREET  
McMAHONS POINT NSW 2060

SURVEY PLAN  
SHOWING DETAIL & LEVELS  
OVER LOT 5 IN D.P.129325,  
LOT 398 & 399 IN D.P.752023  
AND LOT 2 IN D.P.230294  
160 BURWOOD ROAD  
CONCORD NSW 2137

C.M.S. Surveyors  
Pty Limited

ACN: 096 240 201  
PO Box 463 Dee Why  
NSW 2099  
1/32 Campbell Avenue,  
Dee Why NSW 2099  
Telephone: (02) 9971 4802  
Facsimile: (02) 9971 4822  
E-mail: info@cmsurveyors.com.au

LGA: CANADA BAY	SHEET 10 OF 11		
SURVEYED MB	DRAWN CJR	CHECKED MB	APPROVED MJ
SURVEY INSTRUCTION 13040	SCALE 1:200 @ A1	DATE OF SURVEY 12/05/15	
DRAWING NAME 13040detail 3			ISSUE 1
CAD FILE 13040detail 3.dwg			

THIS SHEET IS TO BE READ IN CONJUNCTION WITH NOTES & LEGEND SEE SHEET 11

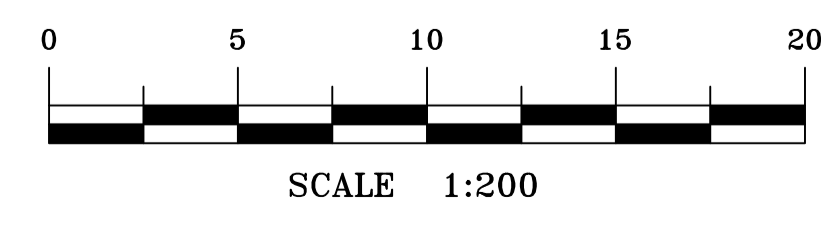

GOVERNERS DRIVE



